

标记	数量	更改文件号	更改内容	姓名	月、日

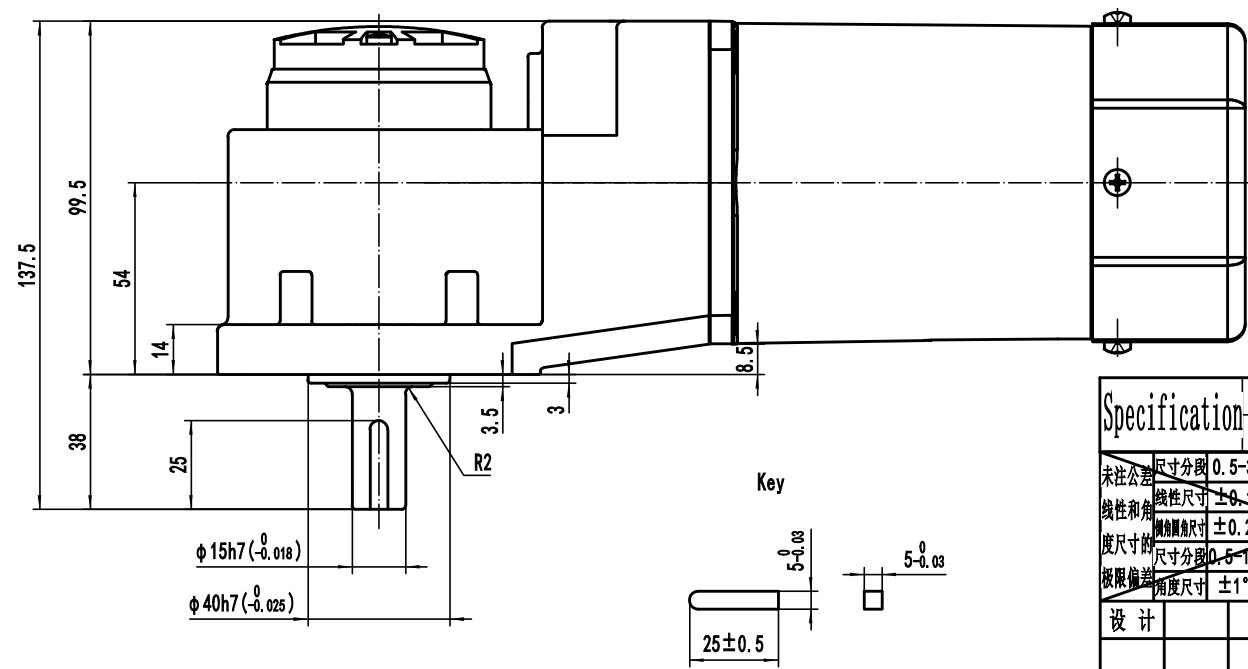
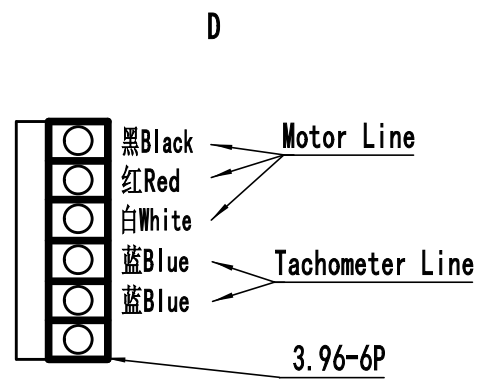
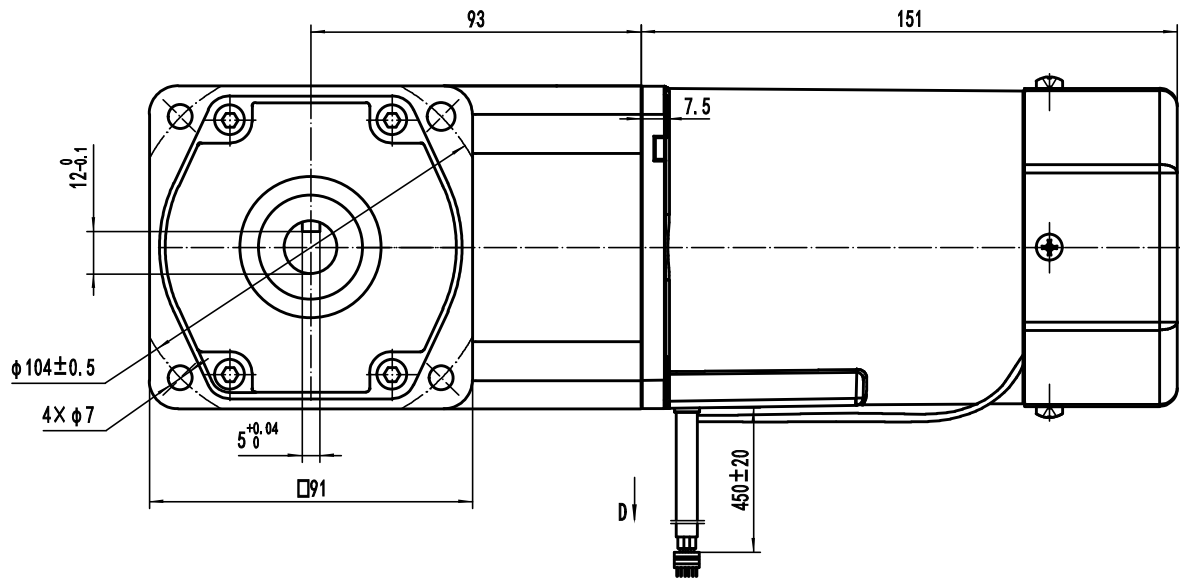

Technical requirements:

1. Trim key C type 5\*25 (GB/T 1096), bring out the shaft sheath  $\phi 15$ ;
2. Motor lead: UL3321/18AWG/600V/150°C, red, white, black;
3. The motor is equipped with 7uF/500V capacitor.

Specification	220V		50		120		36.1		7/500		B	
	Rated voltage (V)		Frequency (Hz)		Rated power (W)		Rated speed(r/min)		Capacitance (uF/V)		Insulation class	
未注公差	尺寸分段	0.5-3	>3-6	>6-30	>30-120	>120-400	>400-1000					
线性尺寸	±0.1	±0.1	±0.2	±0.3	±0.5	±0.8						
角度尺寸	±0.2	±0.3	±1	±2	±2	±2						
极限偏差	尺寸分段	0.5-10	>10-50	>50-120	>120-400	>400						
角度尺寸	±1°	±30'	±20'	±10'	±5'							
设计			标准化				阶段标记	数量	比例	Outline drawing		
审核								1	1:1.5			
工艺			批准				共 1 张	第 1 张				

Zhejiang Linix Motor Co., Ltd.

YY90-220-120NAC/90JZ36RT

借(通)用件登记  
版本号 241129  
年月日启用