

## Typical Performance

- Wide voltage range input (4:1), output: 12W
- Conversion efficiency : 91% (Typ.)
- Isolation voltage :1500Vdc
- Ultra-low standby power consumption:  
0.036W(Typ.)
- Quick start: 1mS (Typ.)
- Working temperature range: -40°C~+85°C
- Input undervoltage, output short circuit, over current, over voltage protection
- Metal shell, low output ripple
- International standard pins, PCB board in-line installation

12W, wide voltage input, isolated regulated single/dual output, DIP package,DC-DC power supply module



RoHS

The output power of UR(A)B\_YMD-12WR3 series products is 12W, 4:1 wide voltage input range, efficiency up to 91%, 1500VDC conventional isolation voltage, allowable operating temperature -40°Cto+85°C, with input under-voltage protection, Output overvoltage, overcurrent, short circuit protection functions, bare metal meets CISPR32/ EN55032CLASSA, widely used in medical, industrial control, electric power, instrumentation, communication, railway and other fields.

## Product Coding Rules

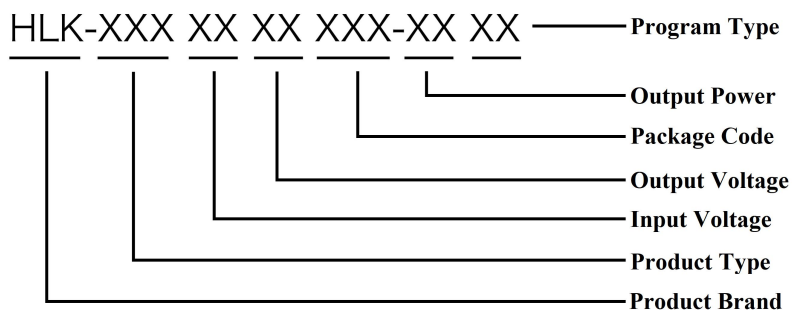

## Product Selection Table

Product model <sup>®</sup>	Input voltage range (Vdc)		Output voltage/current		Ripple and noise	Maximum capacitive	Efficiency @ full load
	Nominal value <sup>®</sup> (range value)	Maximum value	Output voltage (Vdc)	Output current(mA) (Max.Min.)	Full load (mVp-p) (TPY/Max.)	μF Max.	% (Min/TPY)
URB2403YMD-12WR3	24 (9-36)	40	3.3	3000/0	30/50	2500	80/82
URB2405YMD-12WR3			5	2400/0	30/50	2200	83/85
URB2412YMD-12WR3			12	1000/0	50/80	680	87/89
URB2415YMD-12WR3			15	800/0	50/80	470	88/90
URB2424YMD-12WR3			24	500/0	50/80	220	89/91

URA2405YMD-12WR3			±5	±1200/0	30/50	1100	83/85		
URA2412YMD-12WR3			±12	±500/0	50/80	330	86/88		
URA2415YMD-12WR3			±15	±400/0	50/80	220	88/90		
URA2424YMD-12WR3			±24	±250/0	50/80	100	89/91		
URB4803YMD-12WR3	48 (18-75)	80	3.3	3000/0	30/50	2500	80/82		
URB4805YMD-12WR3			5	2400/0	30/50	2200	83/85		
URB4812YMD-12WR3			12	1000/0	50/80	680	87/89		
URB4815YMD-12WR3			15	800/0	50/80	470	88/90		
URB4824YMD-12WR3			24	500/0	50/80	220	89/91		
URA4805YMD-12WR3			±5	±1200/0	30/50	1100	83/85		
URA4812YMD-12WR3			±12	±500/0	50/80	330	86/88		
URA4815YMD-12WR3			±15	±400/0	50/80	220	88/90		
URB4824YMD-12WR3			±24	±250/0	50/80	100	89/91		
URB11003YMD-12WR3			110 (40-160)	180	3.3	3000/0	30/50	2500	80/82
URB11005YMD-12WR3					5	2400/0	30/50	2200	83/85
URB11005V2YMD-12WR3					5.2	2307/0	30/50	2200	83/85
URB11012YMD-12WR3					12	1000/0	50/80	680	87/89
URB11015YMD-12WR3					15	800/0	50/80	470	88/90
URB11024YMD-12WR3	24	500/0			50/80	220	89/91		
URA11005YMD-12WR3	±5	±1200/0			30/50	1100	83/85		
URA11012YMD-12WR3	±12	±500/0			50/80	330	86/88		
URA11015YMD-12WR3	±15	±400/0			50/80	220	88/90		
URA11024YMD-12WR3	±24	±250/0			50/80	100	89/91		

**Note:**1. Due to limited space, the above is just a list of typical products. If you need products other than the list, please contact the sales department of our company.

2. The maximum capacitive load indicates the maximum capacitive load that can be connected to +Vo or -Vo. If it exceeds this value, the product will not be able to start normally.

3. Input voltage exceeding the maximum value may cause permanent damage to the product.

**Test conditions:** Unless otherwise specified, all parameter tests are measured under nominal input voltage, purely resistive rated load and 25°C room temperature.

## Input Features

Project	Working conditions		Min.	Typ.	Max.	Unit
Input current (full load/no load)	24VDC nominal input series, nominal input voltage	3.3V	-	503/1	515/2	mA
		others	-	549/1	602/2	
	48VDC nominal input series, nominal input voltage	3.3V	-	252/0.5	258/1	
		others	-	274/0.5	301/1	
110VDC nominal input series, nominal input voltage	3.3V	-	110/0.3	113/0.5		
	others	-	128/0.3	136/0.5		
Reflected ripple current	24VDC nominal input series, nominal input voltage		-	40	-	mA
	48VDC nominal input series, nominal input voltage		-	30	-	

	110VDC nominal input series, nominal input	-	20	-	
Impulse voltage (Isec.max)	24VDC nominal input series, nominal input voltage	-0.7	-	50	VDC
	48VDC nominal input series, nominal input voltage	-0.7	-	100	
	110VDC nominal input series, nominal input	-0.7	-	200	
Start voltage	24VDC nominal input series, nominal input voltage	-	-	9	
	48VDC nominal input series, nominal input voltage	-	-	18	
	110VDC nominal input series, nominal input	-	-	40	
Input undervoltage protection	24VDC nominal input series, nominal input voltage	5.5	6.5	-	
	48VDC nominal input series, nominal input voltage	12	15.5	-	
	110VDC nominal input series, nominal input	32	36	-	
Start time	Nominal input voltage and constant resistance load	-	1	-	mS
Input filter type		PI type			
Hot plug		Not support			
Remote control (Ctrl)*	Module on	Ctrl floating or connected to TTL high level (3.5-12VDC)			
	Module off	Ctrl is connected to GND or low level (0-1.2VDC)			
	Input current at shutdown	-	0	1	mA

Note: \*Ctrl control pin voltage is relative to input pin GND

## Output Features

Project	Working and testing conditions	+Vo1			-Vo2		
		Min.	Typ.	Max.	Min.	Typ.	Max.
Output load	Load percentage	0%	-	100%	0%	-	100%
Output voltage accuracy		-	±1.0%	±2.0%	-	±2.0%	±3.0%
Linear adjustment rate	Input voltage range	-	±0.2%	±0.5%	-	±1.5%	±2%
Load regulation	20%~100% rated load, balanced load	-	±0.5%	±1%	-	±4.0%	±5.0%
Ripple and noise	Pure resistive load, 20MHz bandwidth, peak-to-peak	-	50mVp-p	80mVp-p	-	50mVp-p	80mVp-p
Startup delay time		-	1ms	-	-	1ms	-
Output voltage regulation	Input voltage range	-	No adjustment end	-	-	No adjustment end	-
Dynamic response step deviation	25% nominal load step	-	±3.0%	±5.0%	-	±3.0%	±5.0%
Dynamic response recovery time		-	300μs	500μs	-	300μs	500μs
Output overvoltage protection	Full voltage range input	110%Vo	-	160%Vo			

Output overcurrent protection	Full voltage range input	110%Io	150%Io	200%Io			
Output short circuit protection	Full voltage range input	Sustainable, self-recovery					

**Note:** ① For product models with output voltage of  $\pm 5\text{VDC}$  and  $\pm 9\text{VDC}$ , under the condition of 0%-5% load, the maximum output voltage accuracy is  $\pm 5\%$ ;  
 ② When tested under 0%-00% load working conditions, the index of load adjustment rate is  $\pm 5\%$ ;  
 ③ 0%-5% load ripple & noise less than or equal to 5% Vo. Ripple and noise test method Twisted pair test method, which can add capacitive load at the output to reduce light load ripple.

## General Features

Project	Working conditions	Min.	Typ.	Max.	Unit
Insulation voltage	Input-output, test time 1 minute, leakage current is less than 1mA	1500	--	--	VDC
Insulation resistance	Input-output, insulation voltage 500VDC	1000	--	--	M $\Omega$
Isolation capacitor	Input-output, 100KHz/0.1V	--	1000	--	pF
Working temperature	Using reference temperature derating curve	-40	--	+85	°C
Storage temperature		-40	--	+125	
Working maximum case temperature		--	--	+100	
Storage humidity	No condensation	5	--	95	%RH
Pin soldering temperature	The solder joint is 1.5mm away from the shell, 10 s	--	--	+300	°C
On-off level	PWM mode	--	250	--	KHz
Vibration		10-55Hz,10G,30Min.alongX,YandZ			
Shell material		Aluminum shell			
Minimum time between failures	MIL-HDBK-217F@25°C	--	2X10 <sup>5</sup>	--	Hrs

## Temperature Characteristic Curve

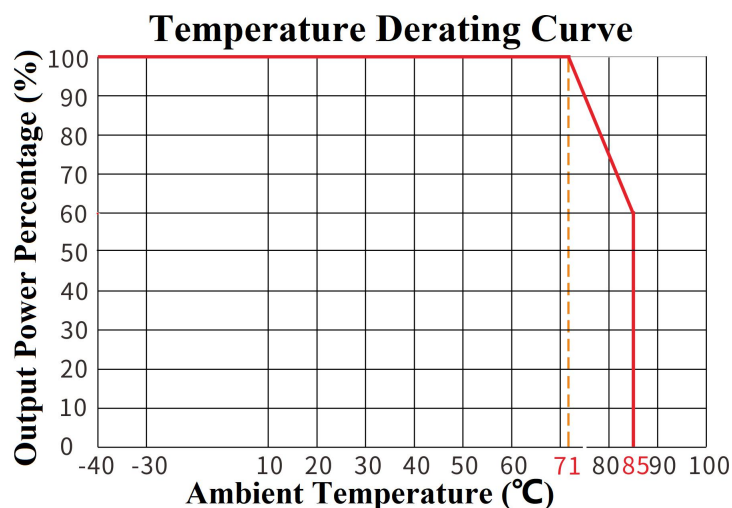

## EMC Peripheral Recommended Circuit

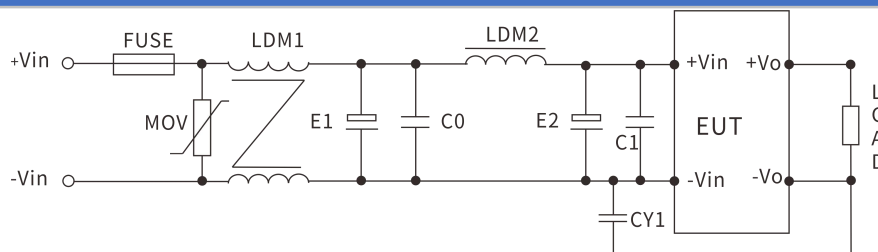

Parameter recommendation: The following are typical parameters, please adjust accordingly according to the actual use environment.

Device code	24V input product	48V input product	110V input product
FMSE fuse	Access the corresponding fuse according to customer needs		
MOV varistor	14D560K	14D101K	14D201K
LDM1 common mode inductance	10mH	15mH	30mH
E1、E2 electrolytic capacitor	100 $\mu$ F/50V	100 $\mu$ F/100V	63 $\mu$ F/200V
C0、C1 ceramic capacitor	1 $\mu$ F/50V	1 $\mu$ F/100V	0.47 $\mu$ F/250V
LDM2 differential mode inductance	10 $\mu$ H	15 $\mu$ H	68 $\mu$ H
CY1 safety Y2 inductance	1nF/250Vac		

## Output Filter Peripheral Recommended Circuit

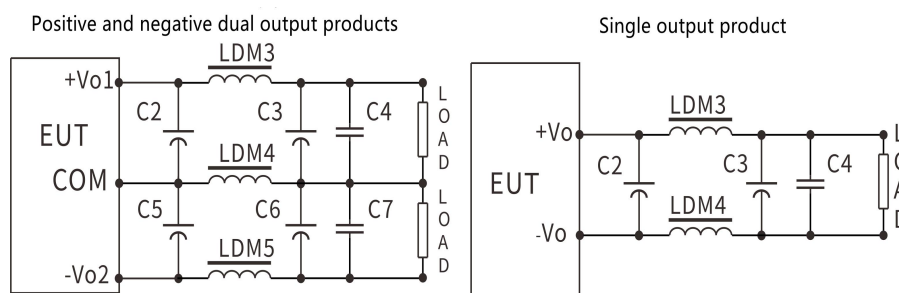

When the requirements for ripple & noise are general, it is recommended to use only C2 and C5 for the periphery; when the requirements for ripple & noise are strict, the circuit shown above is recommended.

- Note:**
- 1.C2, C3, C5, C6 use high-frequency low-resistance electrolytic capacitors, and the total capacity cannot exceed the maximum capacitive load marked in the manual, otherwise the module will not be able to start normally.
  - 2.When the capacitive load is used, the minimum load of 3% must be guaranteed, otherwise the module output will be abnormal.
  - 3.LDM5 is only used for dual output products.

**Parameter recommendation:**

Device code	3.3V output	$\pm$ 5V or 5V output	$\pm$ 9V/12V or 9V/12V output	$\pm$ 15V or 15V output	$\pm$ 24V or 24V output
LDM3 inductance	0.47 $\mu$ H	1 $\mu$ H	2.2 $\mu$ H	2.2 $\mu$ H	4.7 $\mu$ H
LDM4 inductance	0.47 $\mu$ H	1 $\mu$ H	2.2 $\mu$ H	2.2 $\mu$ H	4.7 $\mu$ H
LDM5 inductance	-	1 $\mu$ H	2.2 $\mu$ H	2.2 $\mu$ H	4.7 $\mu$ H
C2, C3 electrolytic capacitor	220 $\mu$ F	220 $\mu$ F	100 $\mu$ F	100 $\mu$ F	68 $\mu$ F
C5, C6 electrolytic capacitor	220 $\mu$ F	220 $\mu$ F	100 $\mu$ F	100 $\mu$ F	68 $\mu$ F
C4, C7 ceramic capacitor	1 $\mu$ F/50V				

## Package Size and Pin Function Diagram

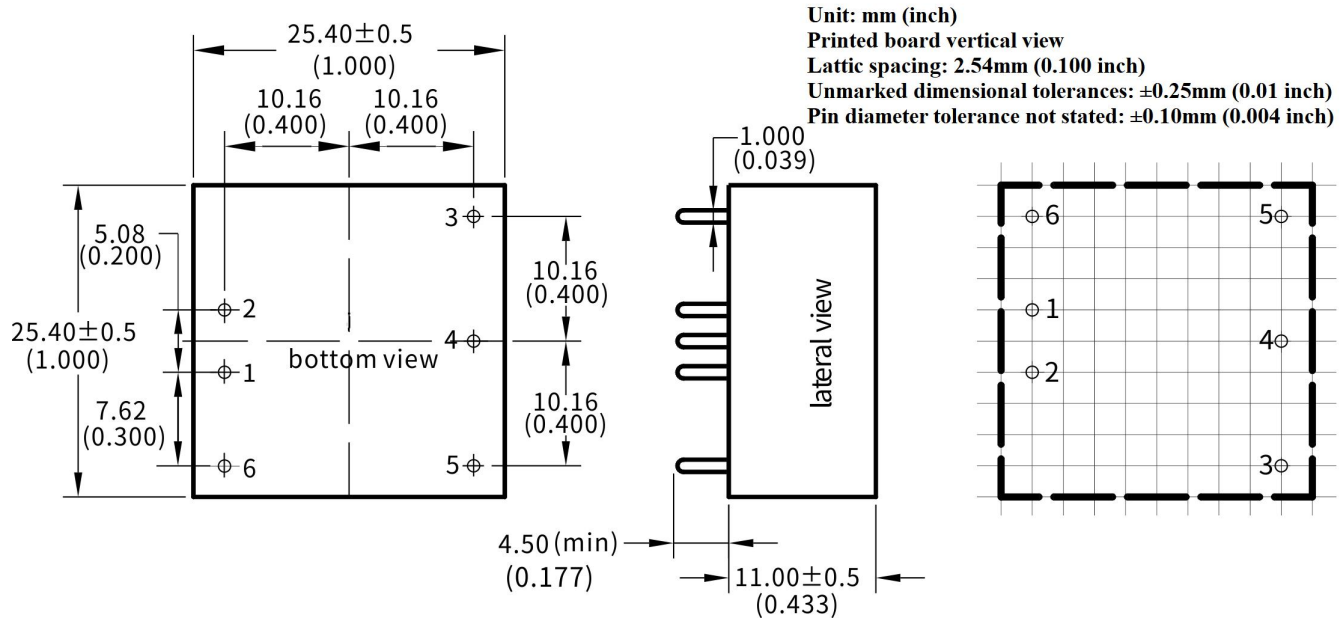

Single(S)	1	2	3	4	5	6
	-Vin	+Vin	+Vo	NP	GND	CTRL
	Input negative	Input positive	Output positive	No contact	Output ground	Remote control
Double(D)	-Vin	+Vin	+Vo1	COM	-Vo2	CTRL
	Input negative	Input positive	Output positive 1	Common	Output negative 2	Remote control

**\*Note:** If the definition of each pin of the power module is inconsistent with the selection manual, the label on the physical label shall prevail.

Such as UR(A)B\_YMD-12WR3, there is no remote control terminal, and the 6-pin is empty.

## Package Description

Package code	LxWxH	
A3	25.4X25.4X11.0mm	1.000X1.000X0.433inch

## Test Application Reference

Recommended test circuit

1. DC/DC test circuit:

Generally recommended capacitors: C1: 47-100 $\mu\text{F}$ ; C2, C3: 10-22 $\mu\text{F}$ .

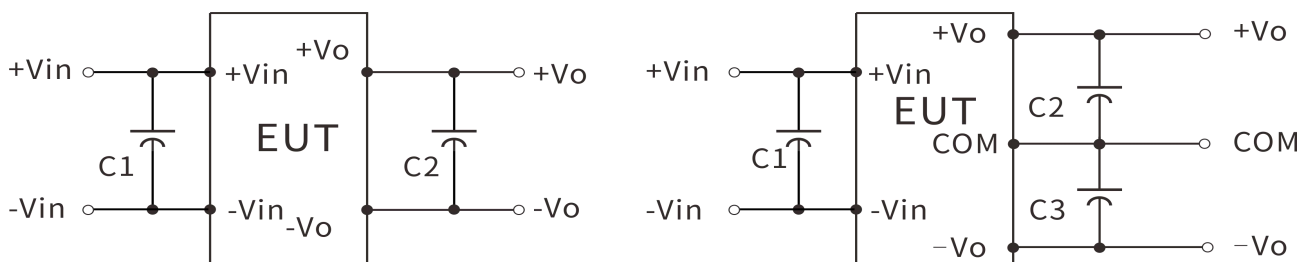

2. Ripple & noise test: (twisted pair method 20MHZ bandwidth)

Testing method:

A) Ripple noise is connected by 12# twisted pair cable, the bandwidth of the oscilloscope is set to 20MHz, the bandwidth of the probe is 100M, and the 0.1uF polypropylene capacitor and the 47uF high-frequency low-resistance electrolytic capacitor are connected in parallel on the probe end, and the oscilloscope sampling uses the Sample sampling mode.

B) Schematic diagram of output ripple noise test:

Connect the power input terminal to the input power supply, and connect the power output to the electronic load through the fixture board. The test uses a 30cm±2cm sampling line to directly sample from the power output port. The power line selects the wire with the insulation sheath of the corresponding wire diameter according to the magnitude of the output current.

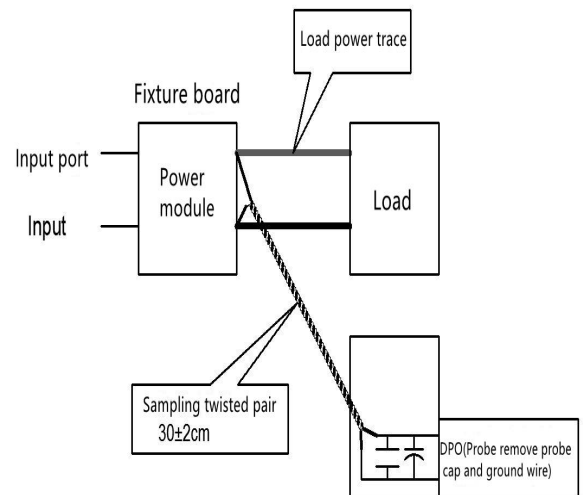

## Contact

### Shenzhen Hi-Link Electronic Co.,Ltd

**Address:** 3rd Floor, Building 1, 1970 Science and Technology Park, No. 112, Minkang Road, Minzhi, Longhua, Shenzhen, Guangdong, China

**Website:** [www.hlktech.net](http://www.hlktech.net)

**Email:** sales@hlktech.com

**Tel:** 0755-23152658