

MH-Z14

Intelligent Infrared Gas Module

User's Manual

# 1. Profile

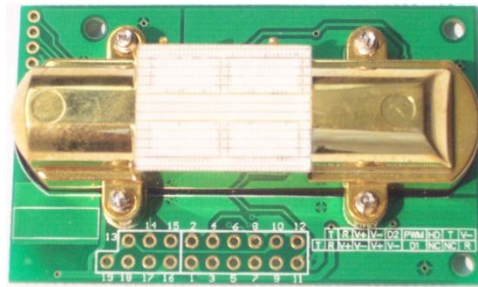

## Main functions and features :

- High sensitivity, High resolution
- Low power consumption
- Output modes: UART, analog voltage signal, PWM wave
- Quick response
- Temperature compensation, excellent linear output
- Good stability
- Long lifespan
- Anti-water vapor interference
- No poisoning

## 2 Main technical parameters

Working voltage	4.5 V ~ 5.5V DC
Average current	< 85 mA
Interface level	3.3 V
Measuring range	0~5%VOL optional
Output signal	PWM
	UART
	0.4-2V DC
Preheat time	3min
Reponse Time	$T_{90} < 90s$
Working temperature	0°C ~ 50°C
Working humidity	0~95%RH
Weight	15 g
Lifespan	>5 year
Dimension	57.5×34.7×16mm (L×W×H)

Target Gas	Measuring Range	Accuracy	Mark
Carbon Dioxide (CO2)	0~2000ppm	±(50ppm +5%reading g value)	Temperature compensation
	0~5000ppm		Temperature compensation
	0~1%VOL		Temperature compensation
	0~3%VOL		Temperature compensation
	0~5%VOL		Temperature compensation

### 3. Structure

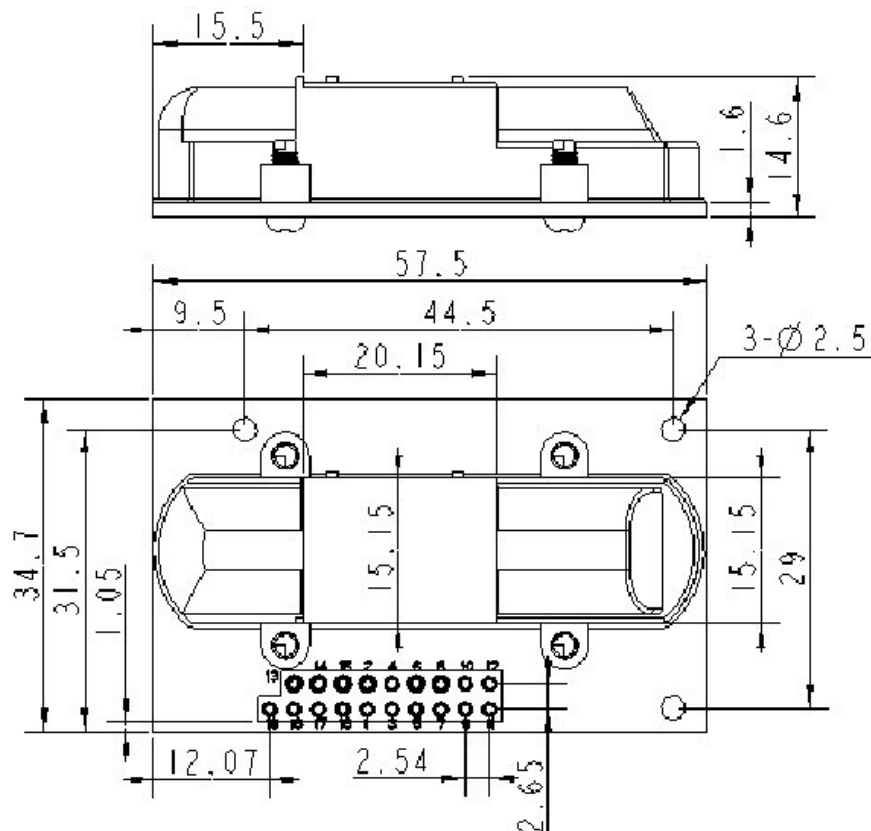

## 4. Definition for pins

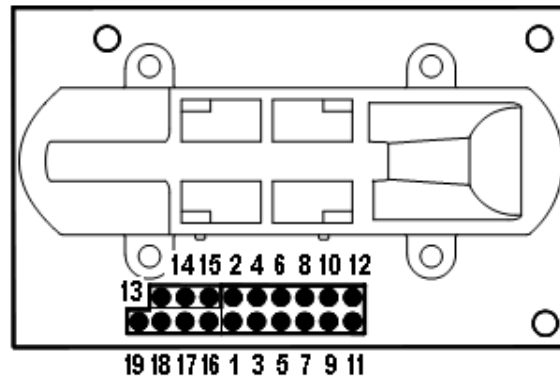

PIN	Description
Pad1、 Pad15、 Pad17	Vin (input voltage 4.5V~5.5V)
Pad2、 Pad3、 Pad12、 Pad16	GND
Pad4	Vout2 (0.4~2V)
Pad5	Vout1 (0~2.5V)
Pad6	PWM
Pad8	HD
Pad7、 Pad9	NC
Pad11、 Pad14、 Pad18	UART (RXD) 0~3.3V input digital
Pad10、 Pad13、 Pad19	UART (TXD) 0~3.3V output digital

## 5. Circuit

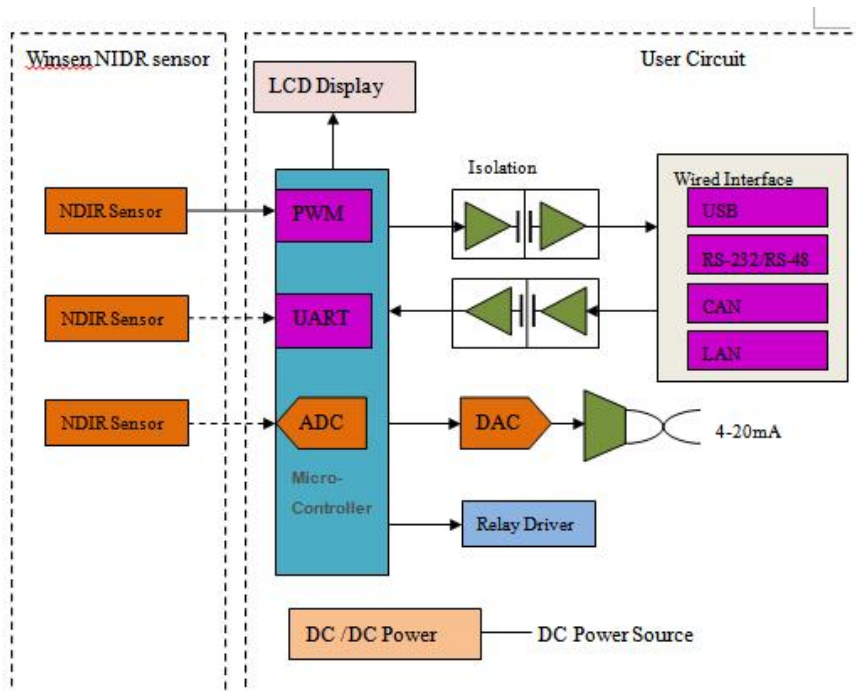

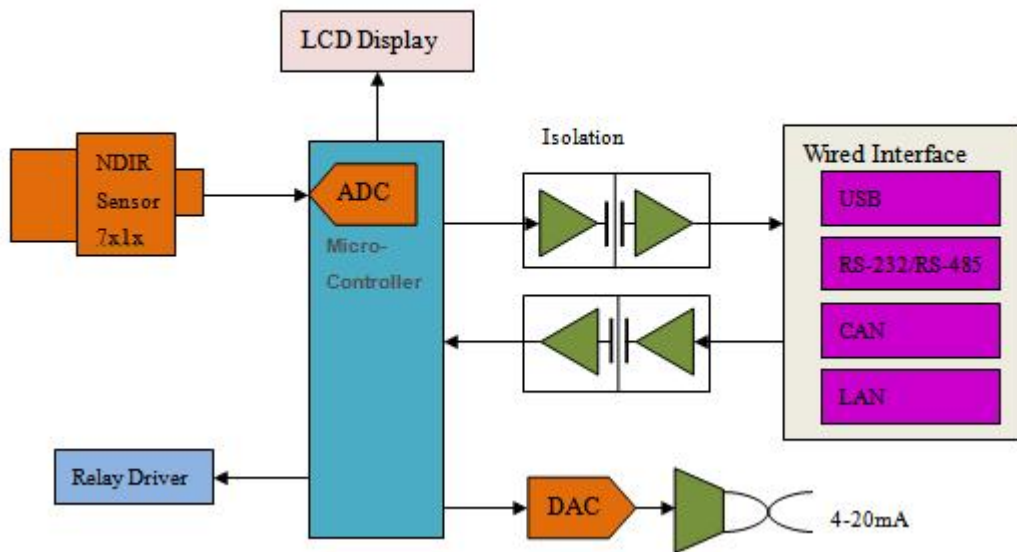

## 6. Operating instruction

### 6.1 Analog output connections

The output value of Vout1 is 0-2.5V, which stands for 0 to full range.

The output value of Vout2 is 0.4-2V, which stands for 0 to full range.

Vin -5V

GND- Power Ground

Vout2-ADC input

After preheating, the value of output voltage from Vout2 represents gas concentration.

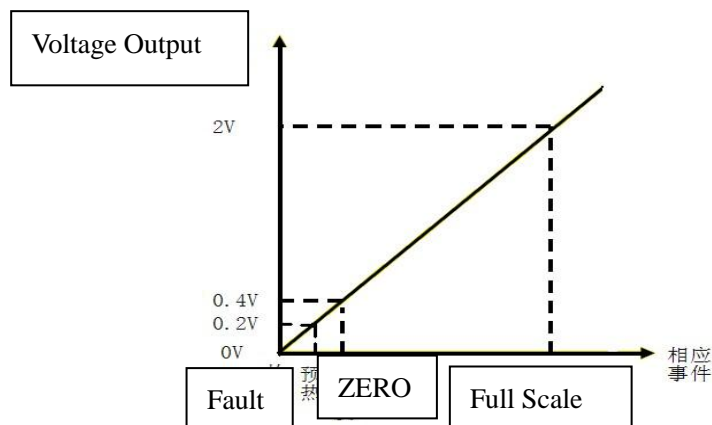

### 6.2 PWM output (taking PWM output from 2000ppm as example):

CO2 output range: 0ppm-2000ppm

Cycle: 1004ms  $\pm$  5%

High level output for beginning: 2ms (in name)  
 Middle of cycle: 1000ms ± 5%  
 Low level output for ending: 2ms (in name)  
 Account formula for CO2 concentration which gets through PWM:

$$C_{ppm} = 2000 \times (T_H - 2ms) / (T_H + T_L - 4ms)$$

Among:

$C_{ppm}$  is calculated CO2 concentration, unit is ppm;

$T_H$  is time for high level during an output cycle;

$T_L$  is time for low level during an output cycle.

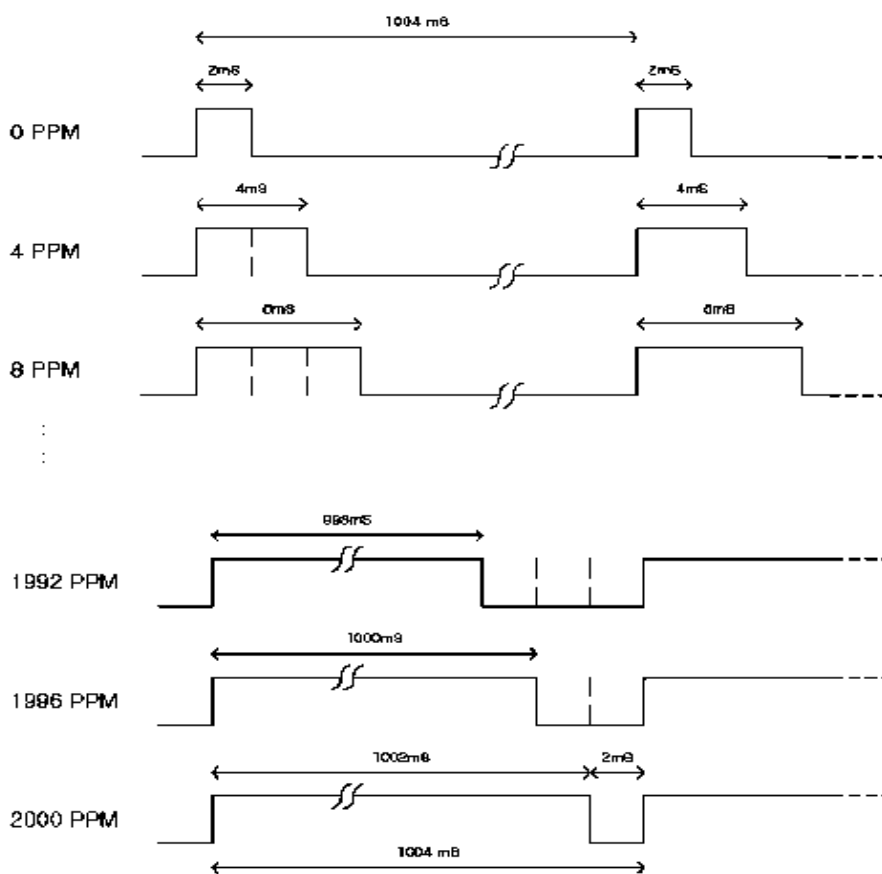

### 6.3 Digital connects:

Vin-5V power

GND- Power Ground

RXD connect sensor TXD

TXD connect sensor RXD

You can read gas concentration via Uart, no need to calculate.

#### 6.3.1 Communication protocol

## 1. General Settings

Baud rate	9600
Date byte	8 byte
Stop byte	1byte
Calibrate byte	no

## 2. Command

Each command or return:

Contains 9 bytes (byte 0 ~ 8)

starting byte fixed 0 XFF

command contains sensor number (factory default to 0 x01)

to check and end

### Command List:

0x86	Gas concentration
0x87	Calibrate zero point (ZERO)
0x88	Calibrate span point (SPAN)

### Read gas concentration

Send command								
Byte0	Byte1	Byte2	Byte3	Byte4	Byte5	Byte6	Byte7	Byte8
Starting byte	Sensor No.	command	-	-	-	-	-	Check value
0XFF	0x01	0x86	0x00	0x00	0x00	0x00	0x00	0x79

### Return value

Return								
Byte0	Byte1	Byte2	Byte3	Byte4	Byte5	Byte6	Byte7	Byte8
Starting byte	command	High level concentration	Low level concentration	-	-	-	-	Check value
0XFF	0x86	0x02	0x60	0x47	0x00	0x00	0x00	0xD1

**Gas concentration= high level \*256+low level**

### Calibrate zero point

Send command								
Byte0	Byte1	Byte2	Byte3	Byte4	Byte5	Byte6	Byte7	Byte8
Starting byte	Sensor No.	command	-	-	-	-	-	Check value
0XFF	0x01	0x87	0x00	0x00	0x00	0x00	0x00	0x78

**No return value**

## Calibrate span point

Send command								
Byte0	Byte1	Byte2	Byte3	Byte4	Byte5	Byte6	Byte7	Byte8
Starting byte	Sensor No.	command	High level span point	Low level span point	-	-	-	Check value
0xFF	0x01	0x88	0x07	0xD0	0x00	0x00	0x00	0xA0

## No return value

### 3. Calibration and calculation

The checksum = (invert (byte 1 +... + 7)) + 1

#### Reading gas concentration:

Send command								
Byte0	Byte1	Byte2	Byte3	Byte4	Byte5	Byte6	Byte7	Byte8
Starting byte	Sensor No.	command	-	-	-	-	-	Check value
0xFF	0x01	0x86	0x00	0x00	0x00	0x00	0x00	0x79

#### Except byte 0 ,add the other bytes together

$$0x1 + 0x86 + 0 + 0 + 0 + 0 + 0 + 0 = 0x87$$

#### Get the value from the first step, then invert it.

$$0xff - 0x87 = 0x78$$

#### The second value plus one

$$0x78 + 0x01 = 0x79$$

#### Program :C language

```
char getChecksum(char *packet)
{
    char i, checksum;
    for(i = 1; i < 8; i++)
    {
        checksum += packet[i];
    }
    checksum = 0xff - checksum;
    checksum += 1;
    return checksum;
}
```



## 7. Notes for maintenance

7.1 The sensor should be calibrated regularly. The cycle time is better to be no more than 6 months.

7.2 Do not use the sensor in the high dusty environment for long time.

7.3 Please use the sensor with correct power supply.

7.4 Forbidden to cut the sensor pin.

