

NC5039 SPECIFICATIONS

MOTOR TYPE	Permanent Magnet Motor
Reduction type	Worm Gear Reduction
Rated Voltage(V)	12V
Stall Torque(N·m)	≥2.5
Stall Current (A)	≤5
Unload Specs	
Speed (r/min)	45±5rpm
Current (A)	≤1A

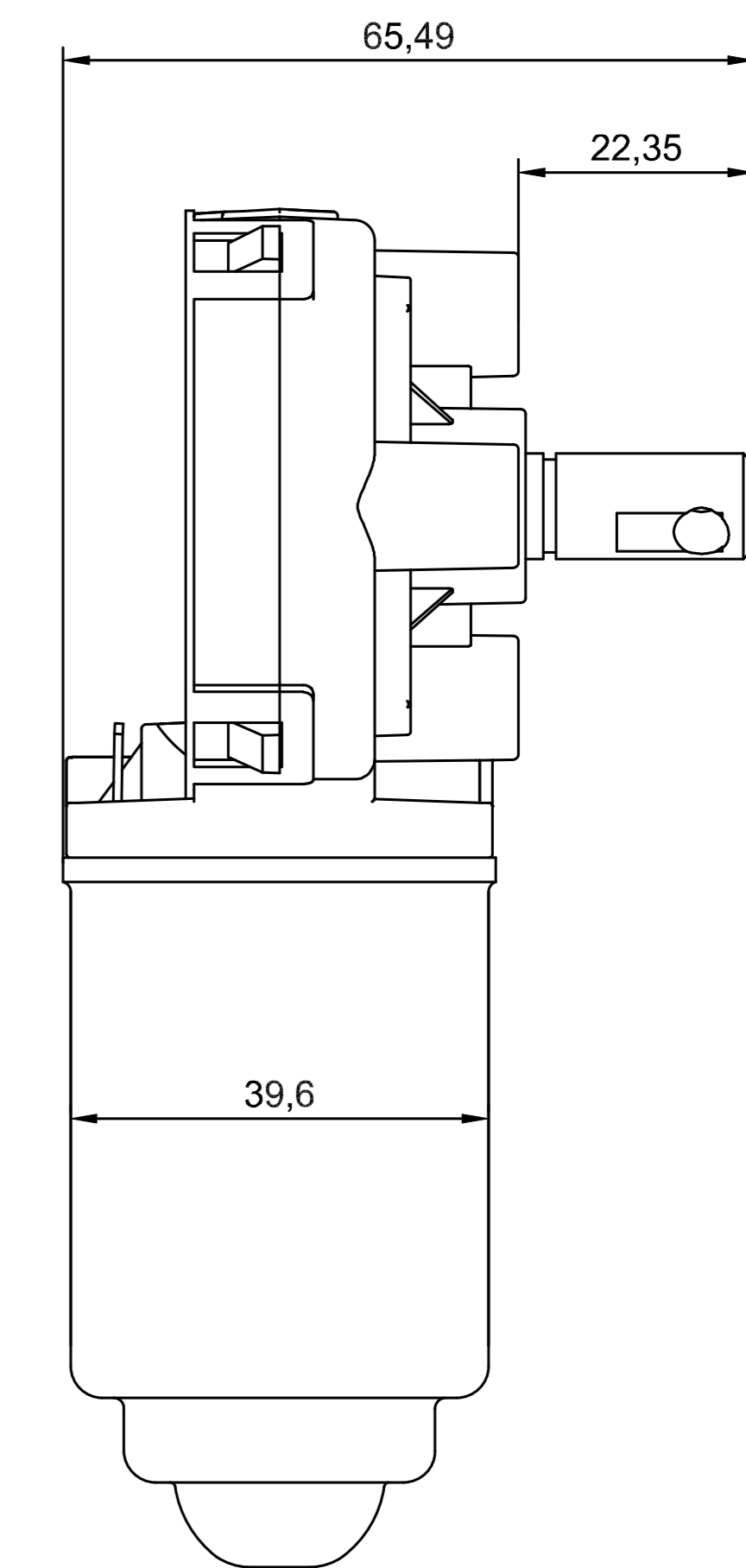
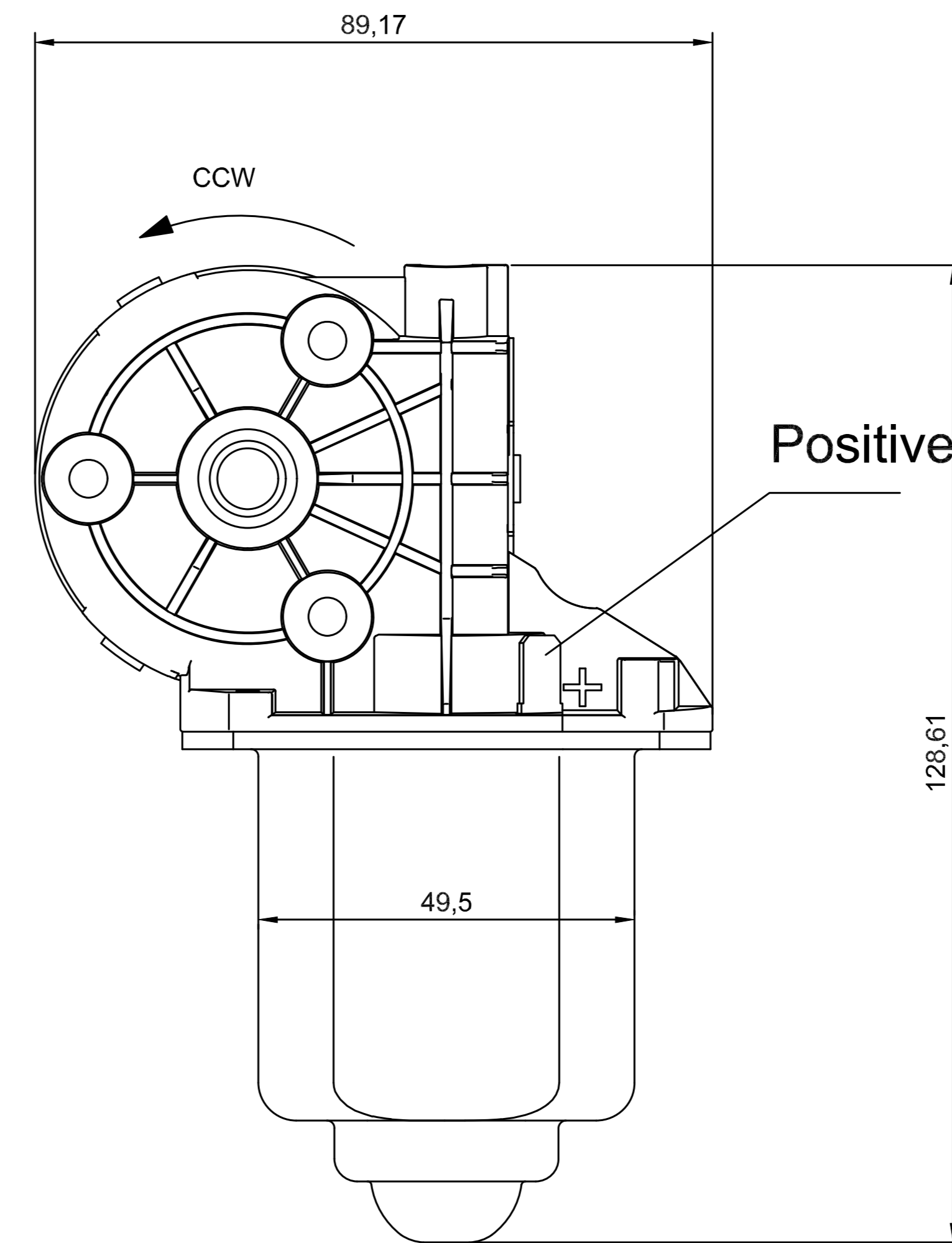
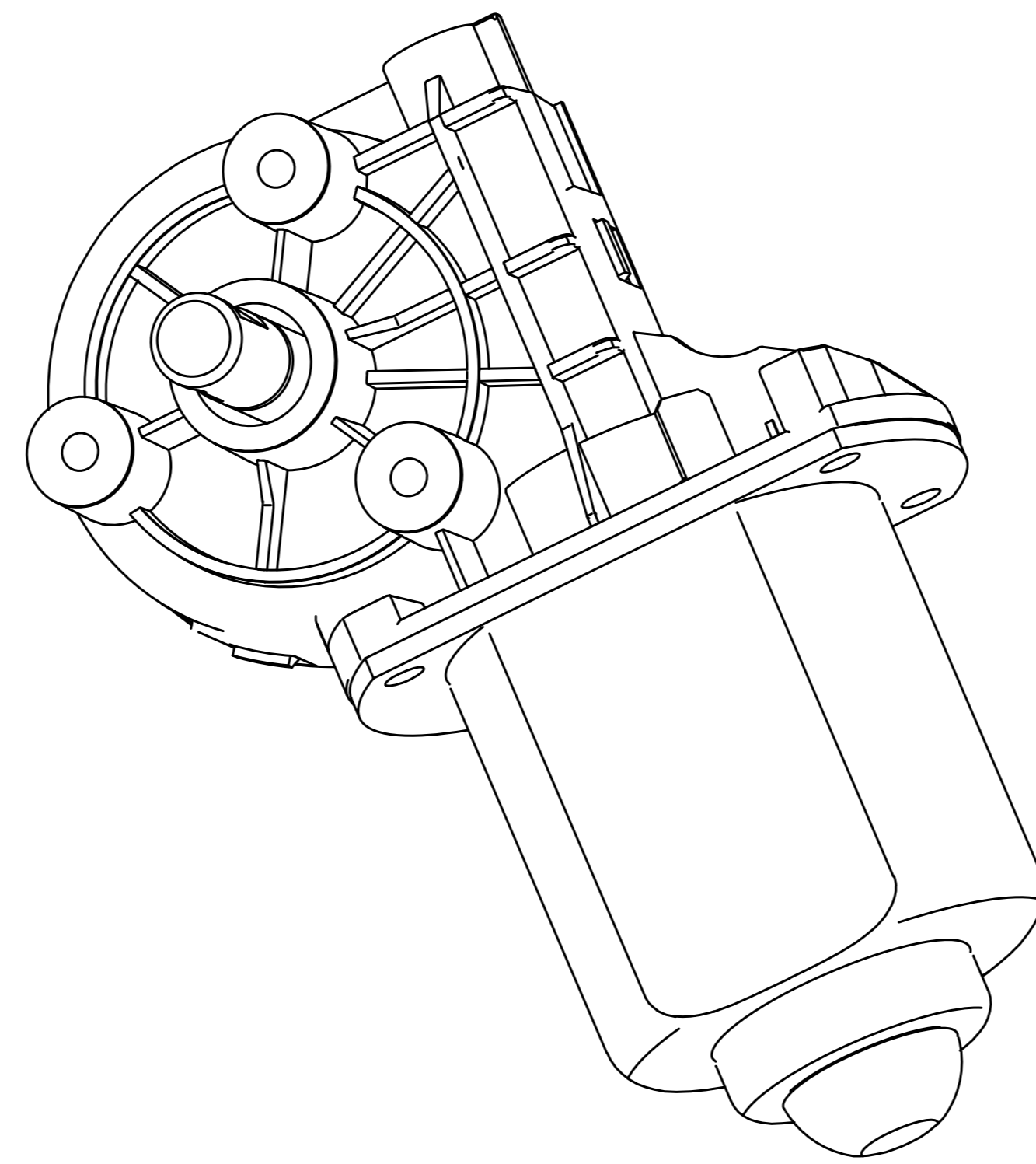

Technical requirement:

1. Main technical parameters of the motor as above table;
2. The motor rotate Anti-clockwise when the positive electrode of the power supply is connected to the positive electrode of the motor , facing the output shaft;
3. Grease should be applied to the worm wheel, worm rod and related mechanical moving parts during the motor assembly;
4. The connecting part of the screw shall be fastened during the motor assembly and not loose;
5. During the assembly test,keep distance 30cm the noise is less than 50dB, and the feel is smooth.

版本控制号

签字

日期

				图号	NC5039-WX		名称	外形图
标记	更改单号	签名	日期	阶段标记	S		材料	
设计		审核		版本	重量	比例		
校对		标准化		A1		1:1		
会签		批准		共 1 张 第 1 张				Cirolla