

NC231 SPECIFICATIONS	
MOTOR TYPE	Permanent magnet motor
Reduction type	Worm gear reduction
Rated Voltage(V)	12V
Stall torque(N·m)	≥6
Stall current (A)	≤12
Unload Specs	
Speed (r/min)	60±5rpm
Current (A)	≤2A

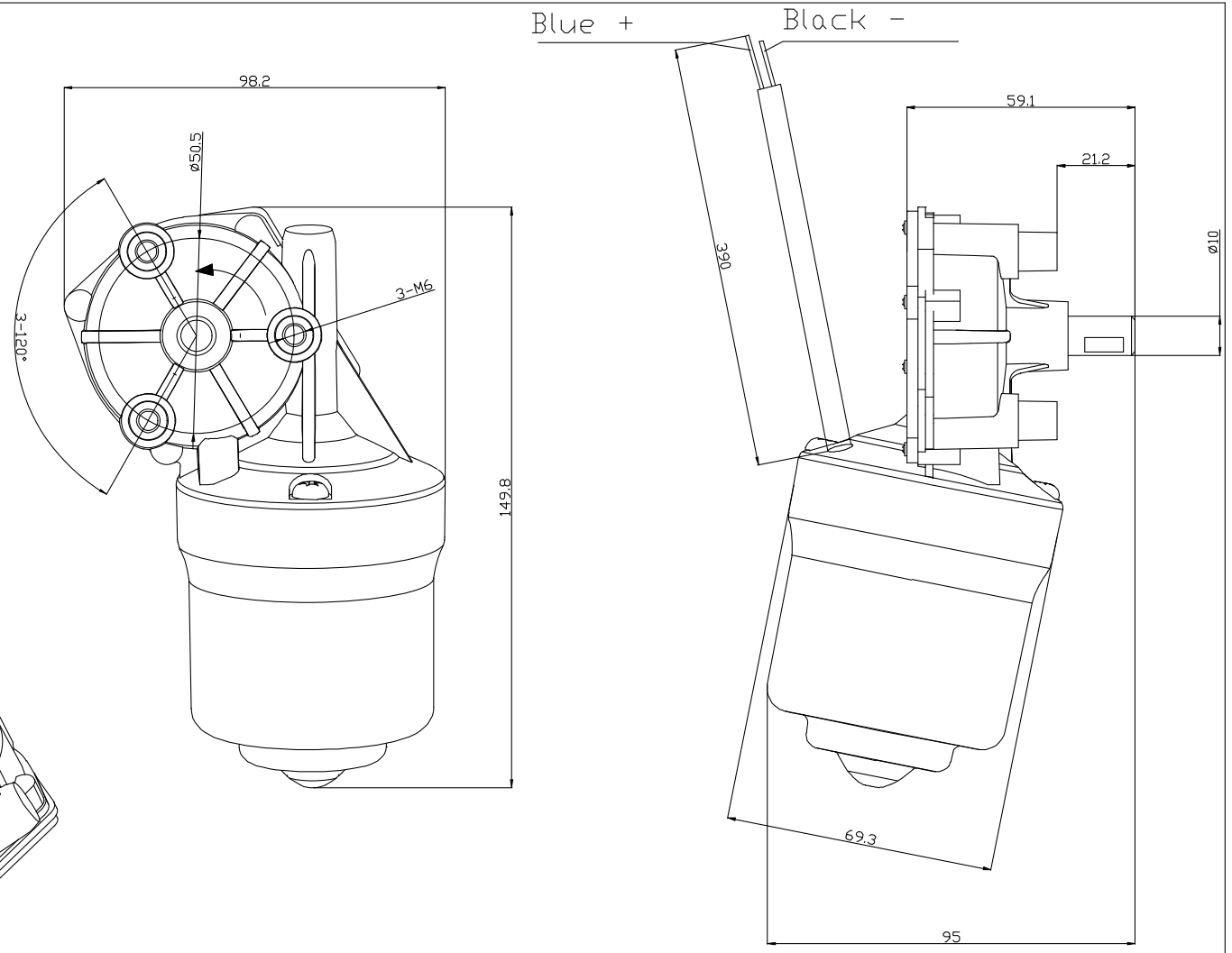
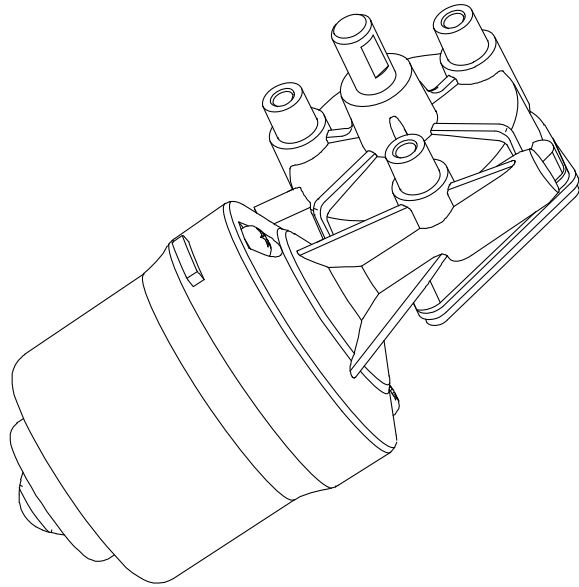

Technical requirement:

1. Main technical parameters of the motor as above table;
2. The motor rotate Anti-clockwise when the positive electrode of the power supply is connected to the positive electrode of the motor , facing the output shaft;
3. Grease should be applied to the worm wheel, worm rod and related mechanical moving parts during the motor assembly;
4. The connecting part of the screw shall be fastened during the motor assembly and not loose;
5. During the assembly test,keep distance 30cm the noise is less than 50dB, and the feel is smooth.

借 (通) 原 件 登 记
旧版图总号
底图总号
签 字
日 期
档案员
档案员

						CIROLLA MOTOR	
						NC231-WX-12V	
设计	日期	设计日期	图样标记	重量	比例		
			图样标记 S		1:1		
			共 页数 张	第 页码 张			