

# 混合式步进电机规格书

## HYBRID STEPPING MOTOR SPECIFICATION

外形图 (DIMENSIONS) unit=mm

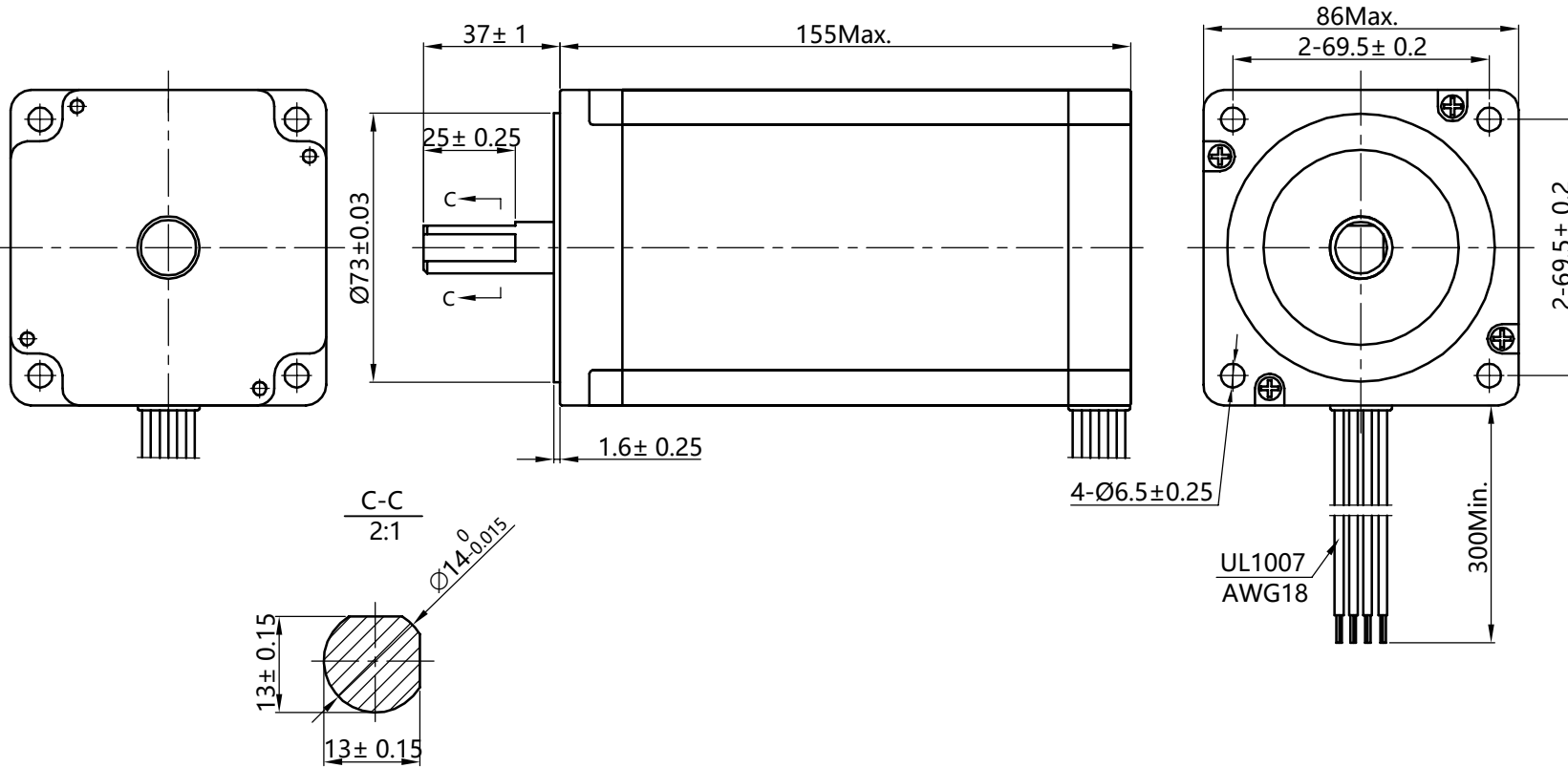

电气原理图

Wiring Diagram

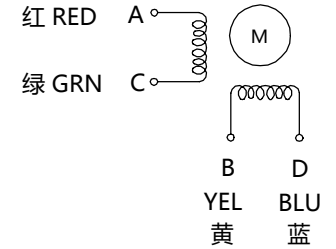

励磁顺序vs.旋转方向

Exciting Sequence vs. Direction of Rotation

STEP	A	B	C	D	
1	+	+	-	-	CCW ↑
2	-	+	+	-	
3	-	-	+	+	
4	+	-	-	+	

CW  
↓

从安装面看为顺时针方向

Clockwise view from mounting side

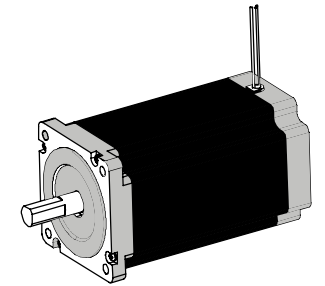

1、相数 Number of Phase	2				
2、步距角 Step Angle	1.8° deg.				
3、额定电压 Rated Voltage	4.08 V				
4、额定电流/相 Rated Current/Phase	6 A (峰值 Peak Value)				
5、相电阻 Phase Resistance	0.68 Ω ± 0.1(20°C)				
6、相电感 Phase Inductance	9 mH ± 20%(1kHz 1V RMS)				
7、保持力矩 Holding Torque	13 N.m				
8、绝缘等级 Insulation Class	B (130°) ;温升 80K Max.				
9、重量 Weight	5.6 kg				
<b>规格 Specifications</b>		<b>备注 Comment</b>			

版本 REV.	变更内容 REVISION RECORD	日期 DATE
设计 DESIGN	常州精控电机电器有限公司 www.jkongmotor.com	
标准化 STANDARD		
工艺 TECHNOLOGY		
审核 CHECK		
批准 APPROVE		

**规格书**  
Specification

品名 TITLE	步进电机 STEPPING MOTOR				
图号 DWG.NO.	JK86HS155-6004				
材料 MATERIAL	变更标识 ECN SIGN	页 SHEET	SIZE	A4	
版本 REV.	A	比例 SCALE	1:2	1 of 1	