

混合式步进电机规格书

HYBRID STEPPING MOTOR SPECIFICATION

外形图 (DIMENSIONS) unit=mm

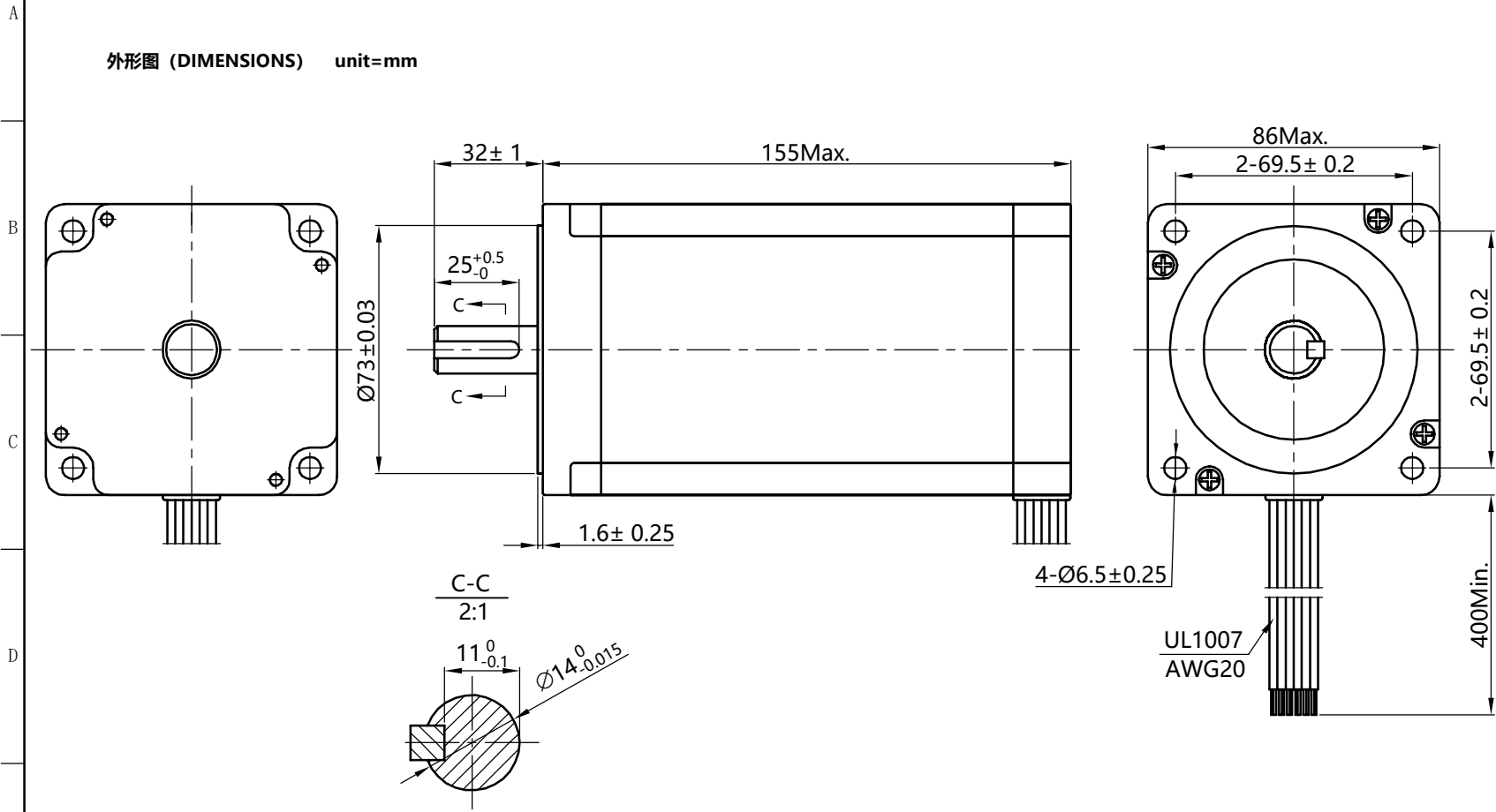

电气原理图

Wiring Diagram

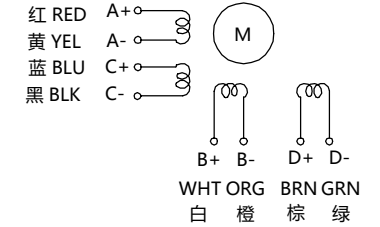

励磁顺序vs.旋转方向

Exciting Sequence vs. Direction of Rotation

STEP	A	B	C	D	
1	+	+	-	-	CCW ↑ CW
2	-	+	+	-	
3	-	-	+	+	
4	+	-	-	+	

从安装面看为顺时针方向

Clockwise view from mounting side

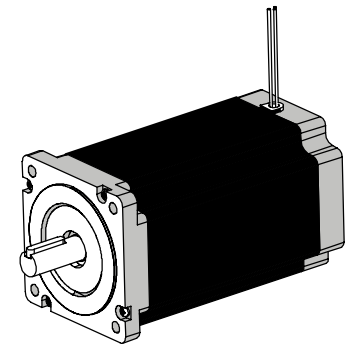

1、相数 Number of Phase	4		
2、步距角 Step Angle	1.8° deg.		
3、接线方式 Wiring	PARALLEL 并联	UNIPOLAR 单极	SERIES 串联
4、额定电压 Rated Voltage	3.67 V	5.25 V	7.35 V
5、额定电流/相 Rated Current/Phase	5.88 A	4.2 A	2.94 A
6、相电阻 Phase Resistance	0.625 Ω	1.25 Ω	2.5 Ω
7、相电感 Phase Inductance	8 mH	8 mH	32 mH
8、保持力矩 Holding Torque	12.2 N.m	8.5 N.m	12.2 N.m
9、绝缘等级 Insulation Class	B (130°) ;温升 80K Max.		
10、重量 Weight	5.3 kg		

规格 Specifications

备注 Comment

版本 REV.	变更内容 REVISION RECORD	日期 DATE
设计 DESIGN	常州精控电机电器有限公司 www.jkongmotor.com	规格书 Specification
标准化 STANDARD		
工艺 TECHNOLOGY		
审核 CHECK		
批准 APPROVE		

品名 TITLE	步进电机 STEPPING MOTOR			
图号 DWG.NO.	JK86HS155-4208			
材料 MATERIAL	变更标识 ECN SIGN	页 SHEET	SIZE	A4
版本 REV.	A	比例 SCALE	1:2	1 of 1