

混合式步进电机规格书

HYBRID STEPPING MOTOR SPECIFICATION

外形图 (DIMENSIONS) unit=mm

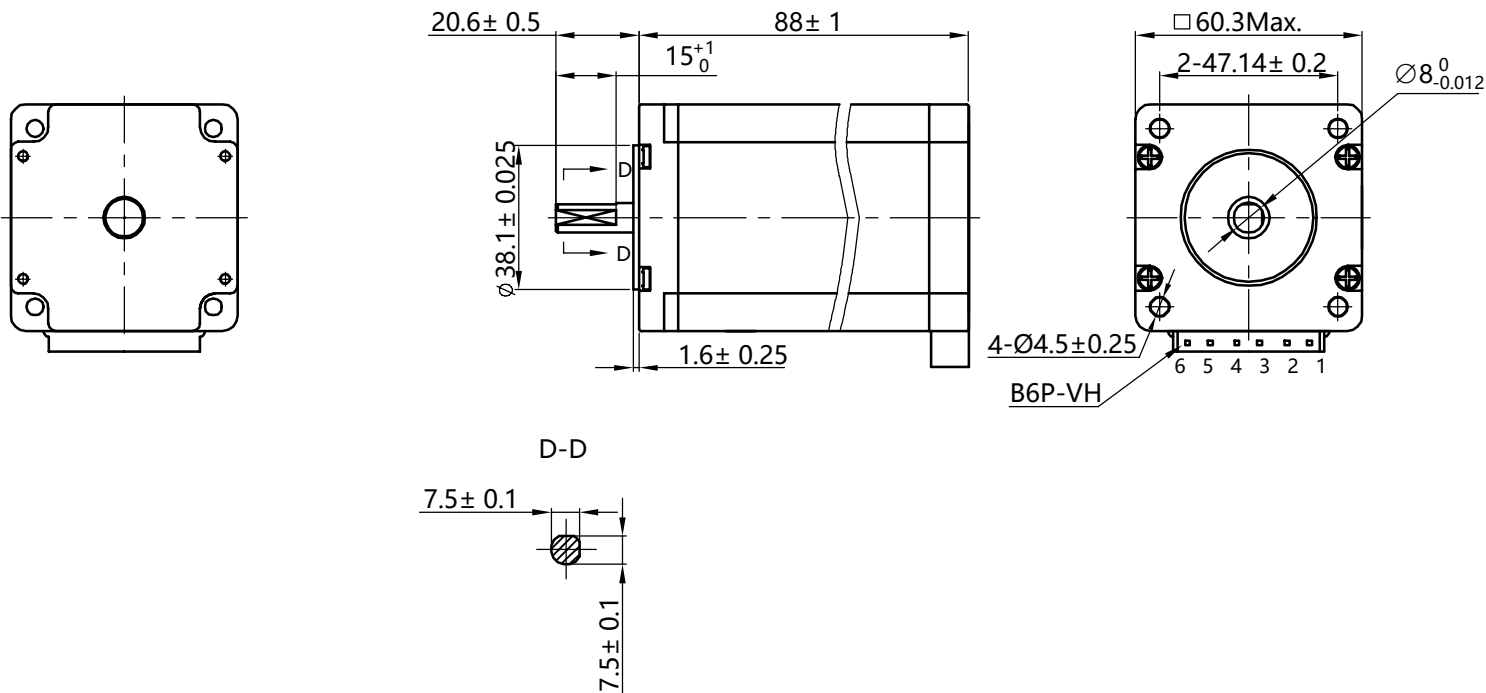

电气原理图

Wiring Diagram

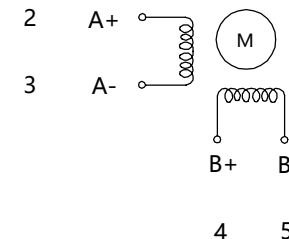

励磁顺序vs.旋转方向

Exciting Sequence vs. Direction of Rotation

STEP	A+	B+	A-	B-	
1	+	+	-	-	CCW ↑
2	-	+	+	-	
3	-	-	+	+	
4	+	-	-	+	

CW
↓

从安装面看为顺时针方向

Clockwise view from mounting side

1、相数 Number of Phase	4				
2、步距角 Step Angle	1.8° deg.				
3、相电压 Phase Voltage	2.6 V				
4、相电流 Phase Current	4.0 A				
5、相电阻 Phase Resistance	0.65 Ω ± 0.1(20°C)				
6、相电感 Phase Inductance	2.4 mH ± 20%(1kHz 1V RMS)				
7、保持力矩 Holding Torque	30 kg.cm				
8、绝缘等级 Insulation Class	B (130°); 温升 80K Max.				
9、重量 Weight	1.05 kg				
规格 Specifications		备注 Comment			

版本 REV.	变更内容 REVISION RECORD		日期 DATE
设计 DESIGN	CZR	2023.06.10	常州精控电机电器有限公司
标准化 STANDARD			www.jkongmotor.com
工艺 TECHNOLOGY			
审核 CHECK			
批准 APPROVE			

规格书
Specification

品名 TITLE	步进电机 STEPPING MOTOR			
图号 DWG.NO.	JK60HS88-4004A-07F			
材料 MATERIAL	变更标识 ECN SIGN	※	SIZE	A4
版本 REV.	A	比例 SCALE	1:2	页 SHEET
				1 of 1