

# 混合式步进电机规格书

## HYBRID STEPPING MOTOR SPECIFICATION

外形图 ( DIMENSIONS ) unit=mm

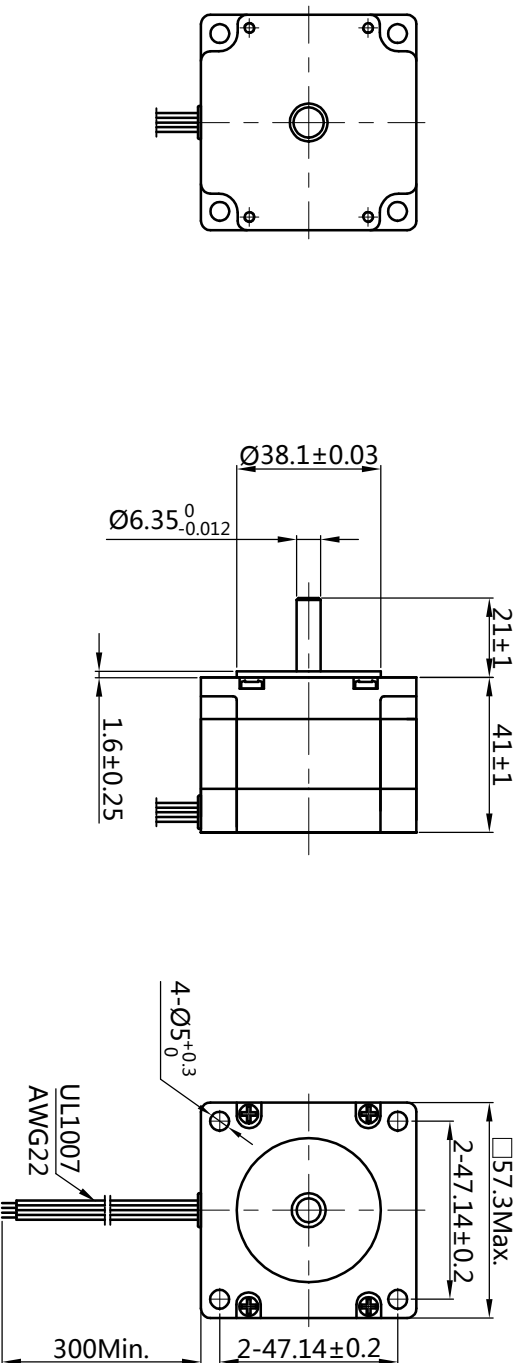

### 电气原理图

Wiring Diagram

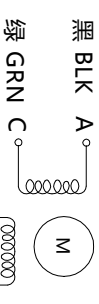

### 励磁顺序vs.旋转方向

Exciting Sequence vs. Direction of Rotation

STEP	A	B	C	D	
1	+	+	-	-	CW
2	-	+	+	-	
3	-	-	+	+	
4	+	-	-	+	
					CCW

从安装面看为顺时针方向

Clockwise view from mounting side

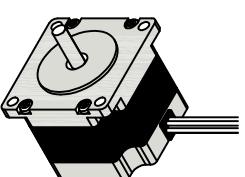

1. 相数 Number of Phase	2				
2. 步距角 Step Angle	1.8° deg.				
3. 额定电压 Rated Voltage	1.96 V				
4. 额定电流/相 Rated Current/Phase	2.8 A (峰值 Peak Value)				
5. 相电阻 Phase Resistance	0.7 Ω±0.1(20°C)				
6. 相电感 Phase Inductance	1.4 mH±20%(1kHz 1V RMS)				
7. 保持力矩 Holding Torque	0.55 N.m				
8. 绝缘等级 Insulation Class	B (130°);温升 80K Max.				
9. 重量 Weight	0.45 kg				

### 规格 Specifications

### 备注 Comment

版本 REV.	变更内容 REVISION RECORD	日期 DATE
设计 DESIGN	YY 2020.06.29	
标准化 STANDARD		
工艺 TECHNOLOGY		
审核 CHECK		
批准 APPROVE		

常州精控电机电器有限公司  
www.jkongmotor.com

### 规格书 Specification

品名 TITLE 步进电机 STEPPING MOTOR

图号 DWG.NO. JK57HS41-2804

材料 MATERIAL	变更标识 ECN SIGN	页 SHEET	尺寸 SIZE
A	1:2	1 of 1	A4