

Typical performance

- Constant voltage input, isolated unregulated output 2W power
- Isolation Voltage: 1500VDC
- Low no-load power consumption: 0.025W (Typ.)
- Efficiency: up to 90% (Typ.)
- Working temperature: -40°C ~ +85°C
- MTBF≥3.5million hours(3500000Hrs)
- Output short circuit protection: continuous short circuit protection, automatic recovery
- Small SIP Package, Plastic Housing
- International standard pin method
- Ripple / Noise (20MHz bandwidth) : 30mVp-p (Typ.)

2W, constant voltage input, isolated unregulated single output DC DC power module

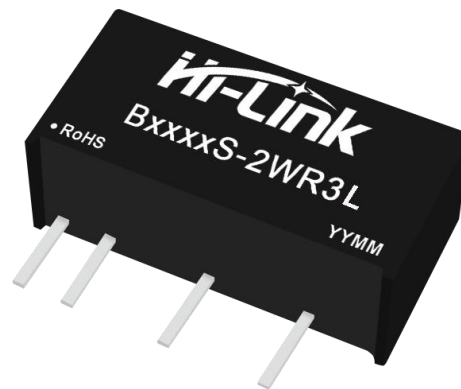

Over temperature protection and output continuous short circuit protection RoHS

B_S-2WR3L series-----is a small size, high-efficiency micro-power, constant voltage input, isolated and unregulated single-channel output provided by Hilink to customers.DC/DC module power supply.

This series of products is specially designed for applications in on-board power systems that need to generate a set of voltages that are isolated from the input power supply. This product is suitable for:

- The voltage of the input power supply is relatively stable (voltage variation range ±10%Vin);
- Isolation is required between input and output (isolation voltage≤1500VDC);
- The requirements for output voltage stability are not high;
- Typical applications: pure digital circuits, general low-frequency analog circuits, relay drive circuits, data exchange circuits, etc.

Product coding rules

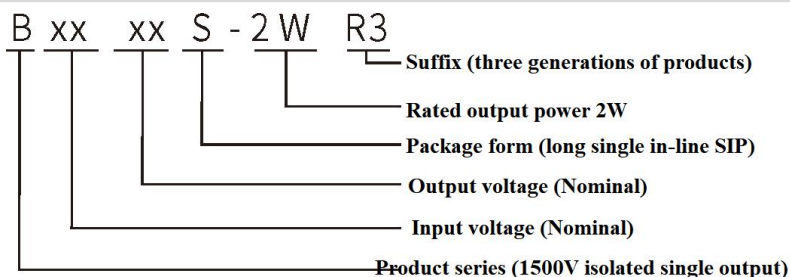

Product selection table

Certification	Product Model [®]	Input voltage range(Vdc)	Output voltage/current		Ripple and noise	Efficiency @ full load	Maximum capacitive load
		Nominal value [®] (range value)	Output voltage (Vdc)	Output current (mA) (Max./Min.)	Fully loaded (mVp-p) Typ./Max.	% (Min./Typ.)	uF
	B0503S-2WR3L	5 (4.5-5.5)	3.3	606/60	30/80	80/83	2400
	B0505S-2WR3L		5	400/40	30/80	85/88	2400
	B0509S-2WR3L		9	222/23	30/80	86/88	1000
	B0512S-2WR3L		12	166/17	30/80	87/89	560

B0515S-2WR3L	9 (8.1~9.9)	15	133/13	30/80	87/89	560
B0524S-2WR3L		24	83/8	30/80	87/89	220
B0903S-2WR3L		3.3	606/60	30/80	80/83	2400
B0905S-2WR3L		5	400/40	30/80	85/88	2400
B0909S-2WR3L		9	222/23	30/80	86/88	1000
B0912S-2WR3L		12	166/17	30/80	87/89	560
B0915S-2WR3L		15	133/13	30/80	87/89	560
B0924S-2WR3L		24	83/8	30/80	87/89	220
B1203S-2WR3L	12 (10.8~13.2)	3.3	606/60	30/80	81/84	2400
B1205S-2WR3L		5	400/40	30/80	86/88	2400
B1209S-2WR3L		9	222/23	30/80	87/89	1000
B1212S-2WR3L		12	166/17	30/80	88/90	560
B1215S-2WR3L		15	133/13	30/80	88/90	560
B1224S-2WR3L		24	83/8	30/80	88/90	220
B1503S-2WR3L	15 (13.5~16.5)	3.3	606/60	30/80	81/84	2400
B1505S-2WR3L		5	400/40	30/80	86/88	2400
B1509S-2WR3L		9	222/23	30/80	87/89	1000
B1512S-2WR3L		12	166/17	30/80	88/90	560
B1515S-2WR3L		15	133/13	30/80	88/90	560
B1524S-2WR3L		24	83/8	30/80	88/90	220
B2403S-2WR3L	24 (21.6~26.4)	3.3	606/60	30/80	81/84	2400
B2405S-2WR3L		5	400/40	30/80	86/88	2400
B2409S-2WR3L		9	222/23	30/80	87/89	1000
B2412S-2WR3L		12	166/17	30/80	88/91	560
B2415S-2WR3L		15	133/13	30/80	88/91	560
B2424S-2WR3L		24	83/8	30/80	88/91	220

Note:

1. Due to limited space, the above is just a list of typical products. If you need products other than the list, please contact the sales department of our company.

2. The maximum capacitive load indicates the maximum capacitive load that can be connected to +Vo or -Vo. If it exceeds this value, the product will not be able to start normally.

Test conditions: Unless otherwise specified, all parameter tests are measured at nominal input voltage, purely resistive rated load and 25°C room temperature.

Input characteristics

Project	Working conditions	Min.	Typ.	Max.	Unit
Input current (Fully loaded/no load)	5VDC input series	--	454/5	--/10	mA
	9VDC input series	--	250/5	--/10	
	12VDC input series	--	186/2	--/5	
	15VDC input series	--	148/2	--/4	
	24VDC input series	--	92/1	--/2	
Reflected Ripple Current		--	15	--	VDC

Impulse voltage (Isec.max)	3.3VDC input series	-0.7	--	5	
	5VDC input series	-0.7	--	9	
	9VDC input series	-0.7	--	15	
	12VDC input series	-0.7	--	18	
	15VDC input series	-0.7	--	21	
	24VDC input series	-0.7	--	30	
Input filter type		Capacitive filtering			
Hot plug		No support			

Output characteristics

Project	Working and testing conditions		Min.	Typ	Max.	Unit
Output load	Load percentage		10	--	100	%
Output voltage	See error envelope curve		--	--	±15.0	%
Linear adjustment rate	Input voltage variation ±1%	3.3V output	--	--	±1.5	%
		Others	--	--	±1.2	%
Load Regulation	10%~100% load	3.3VDC output	--	18	--	%
		5VDC output	--	12	--	%
		9VDC output	--	8	--	%
		12VDC output	--	7	--	%
		15VDC output	--	6	--	%
		24VDC output	--	5	--	%
Ripple & Noise	Pure resistive load, 20MHz bandwidth, peak-to-peak		--	30	80	mVp-p
Temperature Drift	Fully loaded		--	--	±0.03	%/°C
Output short circuit protection	Continuous short circuit protection, automatic recovery					

Note: Ripple and noise test method twisted pair test method.

General characteristics

Project	Working conditions	Min.	Typ	Max.	Unit
Insulation voltage	Input-Output, test time is 1 minute, the leakage current is less than 1mA	1500	--	--	VDC
Insulation resistance	Input-Output, insulation voltage 500VDC	1000	--	--	MΩ
Isolation Capacitor	Input-Output, 100KHz/0.1V	--	40	--	pF
Working temperature	Using the reference temperature derating curve	-40	--	+85	°C
Storage temperature		-40	--	+125	
Shell temperature rise during operation		--	25	--	
Storage humidity	no condensation	5	--	95	%RH
Pin Soldering	The solder joint is 1.5mm away from the shell,	--	--	+300	°C
On-off level	Full load, nominal voltage input	--	100	--	KHz
Shock		10-55Hz, 10G, 30Min.alongX, Y andZ			
Shell material		Black flame retardant heat resistant plastic (UL94V-0)			
Minimum time between failures	MIL-HDFK-217F@25°C	3.5X10 ⁶	--	--	Hrs

Product characteristic curve

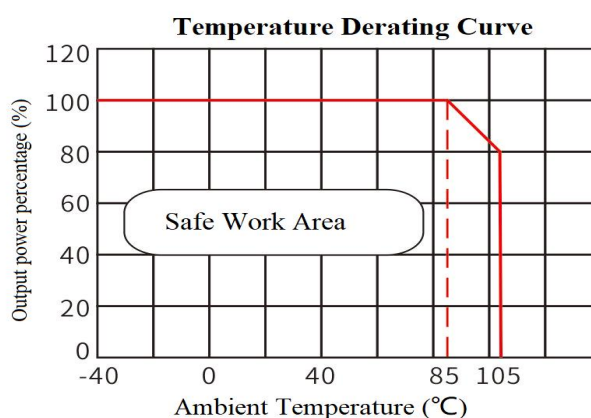
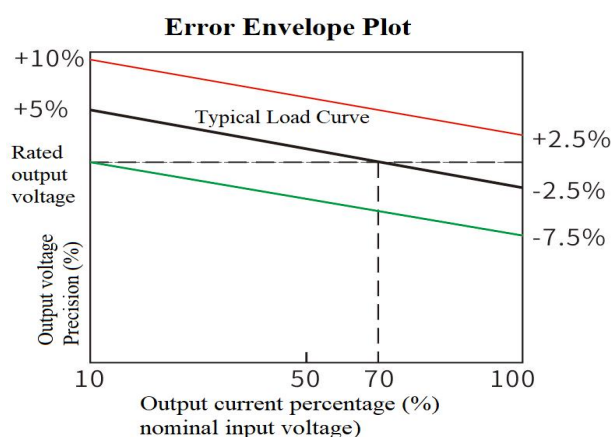

Typical Application Reference Circuit (Recommended Parameters)

1. General application:

If it is required to further reduce the input and output ripple, a capacitor filter network can be connected to the input and output ends, and the application circuit is shown in Figure 1. However, attention should be paid to the selection of appropriate filter capacitors. If the capacitor is too large, it is likely to cause startup problems. For each output, under the condition of ensuring safe and reliable operation, the recommended capacitive load value is shown in Table 1.

Details of recommended capacitive load values (Table 1)

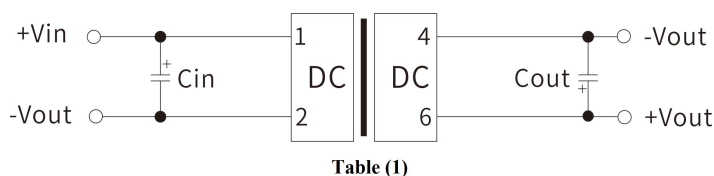

Table (1)

Vin (Vdc)	Cin (uF)	Vo (Vdc)	Cout (uF)
3.3/5	4.7	3.3/5	10
12	2.2	9	4.7
15	2.2	12	2.2
24	1	15	1
-	-	24	0.47

2. EMI typical application circuit

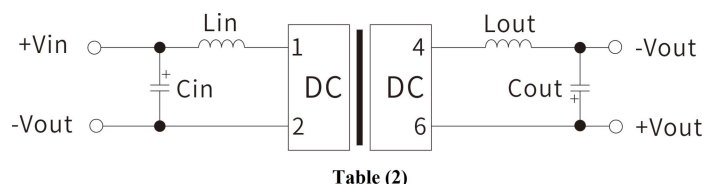

Table (2)

Recommended EMI reference circuit values are detailed (Table 2)

Vin(Vdc)	3.3/5/12/15/24
Cin	4.7uF/50V
Cout	Refer to Table 1
Lin	4.7uH
Lout	4.7uH

3. Output load requirements

In order to ensure that the module can work efficiently and reliably, the minimum output load cannot be less than 10% of the rated load when in use. If the power you need is really small, please connect a resistor in parallel between the positive and negative poles of the output (the sum of the actual power used by the resistor is greater than or equal to 10% of the rated power and the rated power of the selected resistor must be greater than 5 times the actual power used. , otherwise the temperature of the resistor will be higher).

Product appearance size and pin definition, recommended printing layout

1. Physical dimension (unit:mm,tolerance:xx±0.25)

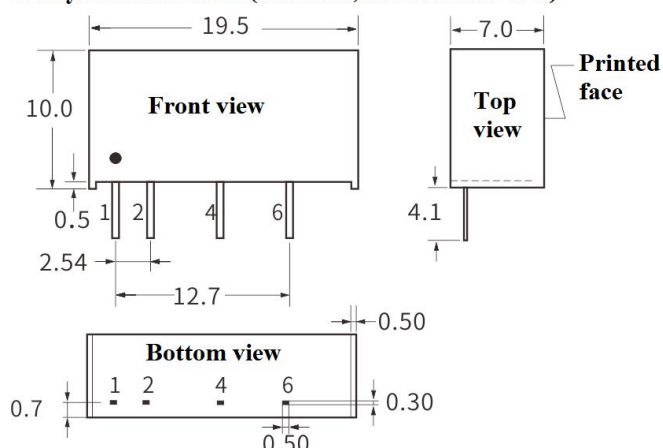

2. Pin definition

1	2	3	4	5	6
+Vin	-Vin	No Pin	-Vout	No Pin	+Vout

3. Recommended print layout

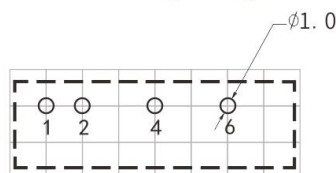

Note: the grid distance is 2.54*2.54mm

***Note: If the definition of each pin of the power module is inconsistent with the selection manual, the label on the physical label shall prevail.**

Package description

Package number	LxWxH	
S	19.5x7.0x10.0mm	0.768×0.276×0.394inch

Test Application Reference

Ripple & noise test: (twisted pair method 20MHZ bandwidth)

Testing method:

1. Ripple noise is connected by 12# twisted pair cable, the bandwidth of the oscilloscope is set to 20MHz, the bandwidth of the probe is 100M, and the 0.1uF polypropylene capacitor and the 4.7uF high-frequency low-resistance electrolytic capacitor are connected in parallel to the probe end, and the oscilloscope sampling uses Sample sampling model.

2. Schematic diagram of output ripple noise test:

3. Connect the power input terminal to the input power supply, and the power output is connected to the electronic load through the fixture board. For the test, use a 30cm±2cm sampling line to directly sample from the power output port. The power line selects the wire with the insulation sheath of the corresponding wire diameter according to the magnitude of the output current.

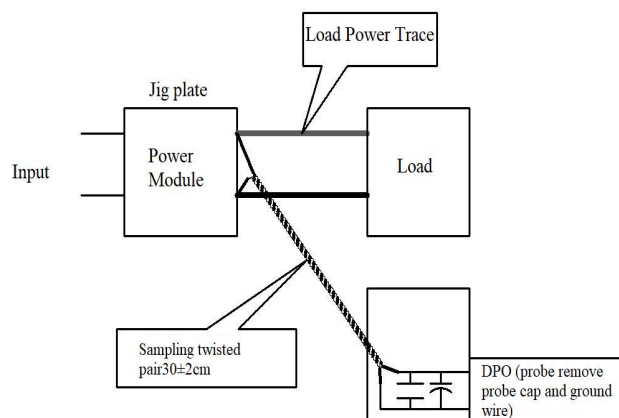

Application Notes

1. Input requirements: ensure that the output voltage fluctuation range of the power supply does not exceed the input requirements of the DC DC module itself, and the output power of the input power supply must be greater than the output power of the DC DC module;
2. Recommended circuit 1 For occasions with general requirements for ripple and noise, a filter capacitor can be connected in parallel at the input end and the output end. The external circuit is shown in Figure (1) below, and the recommended value of the filter capacitor is shown in Table (1) . Output load requirements: try to avoid no-load use. When the actual power consumption of the load is less than 10% of the module's output rated power or there is no-load phenomenon, it is recommended to connect a dummy load at the output end. The dummy load (resistance) can be based on the module's rated power. 5~10% calculation, resistance value= $U_{out}/(1WR3*10\%)$;
3. Overload protection: Under normal working conditions, the output circuit of this product has no protection function for overload conditions, and over-temperature protection will be provided for long-term overload, and the output will be turned off;
4. Output continuous short-circuit protection, automatic recovery.
5. The capacitance value of the external capacitor at the output terminal should not be too large, otherwise it will easily cause overcurrent or poor startup when the module is started;
6. If the product works below the minimum required load, it cannot be guaranteed that the product performance meets all the performance indicators in this manual;
7. The maximum capacitive load is tested under the input voltage range and full load conditions;
8. Unless otherwise specified, all indicators in this manual are measured at $T_a=25^{\circ}\text{C}$, humidity $<75\%RH$, nominal input voltage and output rated load;
9. All index testing methods in this manual are based on the company's standards;
10. Our company can provide product customization, and you can directly contact our technical staff for specific conditions;
11. Product specifications are subject to change without notice.

Contact information

Shenzhen Hi-Link Electronic Co.,Ltd

Address: 3rd Floor, Building 1, 1970 Science and Technology Park, No. 112, Minkang Road, Minzhi, Longhua, Shenzhen

Website: www.hlktech.net

Email: sales@hlktech.com

Telephone: 0755-23152658